

XP Multisafe, Grade S1



Scope of application:

Multisafe is a burglar-proof device for safe deposits and withdrawals of cash values, to be installed under a teller's desktop. Safe casing and electronically controlled access to drawers guarantee appropriate protection of stored values.

Certified by the Institute of Precision Mechanics:

- Burglar-proof quality Grade S1 as per EN 14450.

Product description:

- Three drawers: first for storage of coins and banknotes (operating drawer), third used as cash-in drum (deposit drawer);

When the key lock in the upper drawer is opened, night block can be removed and - in the basic version - the two upper drawers become fully accessible and the deposit drawer is tilted (to enable cash-in).

The deposit drawer becomes fully accessible to authorized personnel after a correct PIN code is entered, and after a specified delay (1 to 99 minutes).



XP Multisafe, Grade S1

- Equipped with certified locks;
- Delayed drawer opening option (1 to 99 mins) in drawers equipped with electronic locks;
- Nighttime blockade (certified class A lock);
- Event log recording (up to 48 events for each drawer fitted with Raptor electronic lock);
- Event log access via external memory and software application;
- PIN code authorization of access to drawers fitted with electronic locks;
- Reentering of PIN code required to reopen drawers fitted with electronic locks;
- Users: 1 manager, 8 tellers, 1 technician;
- Floor-mounting capacity;
- 24-month warranty.

Basic equipment:

- Certified key lock, grade A, with a set of keys;
- Floor attachment anchors;
- Electronic lock in lower deposit drawer;
- Batteries.

Additional options:

- Coins and standard banknotes compartment;
- Coins and banknotes compartment with adjustable partitions, punched;
- Coins and banknotes compartment for deposit drawer;
- Pen + event reading software;
- Replacement of mechanical drawer-blocking lock with electronic KG LOCK, grade B ROTARY BOLT;
- Additional RAPTOR lock in the middle drawer;
- Replacement of RAPTOR lock with electronic KG LOCK EM35-50 with enforcement code + alarm output;
- GM760 seismic sensor;
- GM730 seismic sensor.

XP Multisafe, Grade S1

XP 3-drawer Multisafe

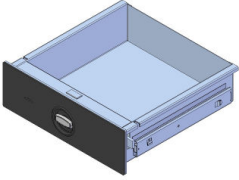
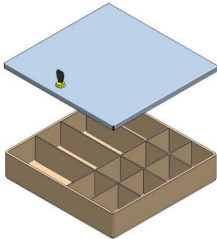
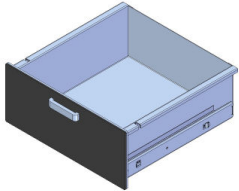
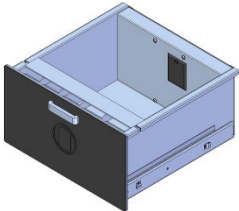
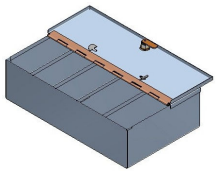
No.	Drawer functions		
	Drawer	Optional	Description
1.			Operating drawer for storage of coins and banknotes. Optionally equipped with a keyed compartment. The internal unit can be used for storage and transport of eight sorted banknote types and eight coin types.
2.			Deposit drawer
3.			Cash-in slot drawer is fitted with a two-step opening mechanism. Partial opening to deposit cash. Full opening to remove the deposit unit.

Technical data:

Model	Outside dimensions [mm]			Weight [kg]	
	Height	Width	Depth		
3-drawer Multisafe	630	500	475	100	
Drawer type	Inside dimensions of drawers			Drawer accessories (optional)	
	Height	Width	Depth		
1.	operating drawer	120	390	370	coins and banknotes compartment
2.	deposit drawer	165	390	420	none
3.	deposit drawer	180	390	340	deposit opening + coins and

XP Multisafe, Grade S1

Dimensions of the unit with extended drawers:

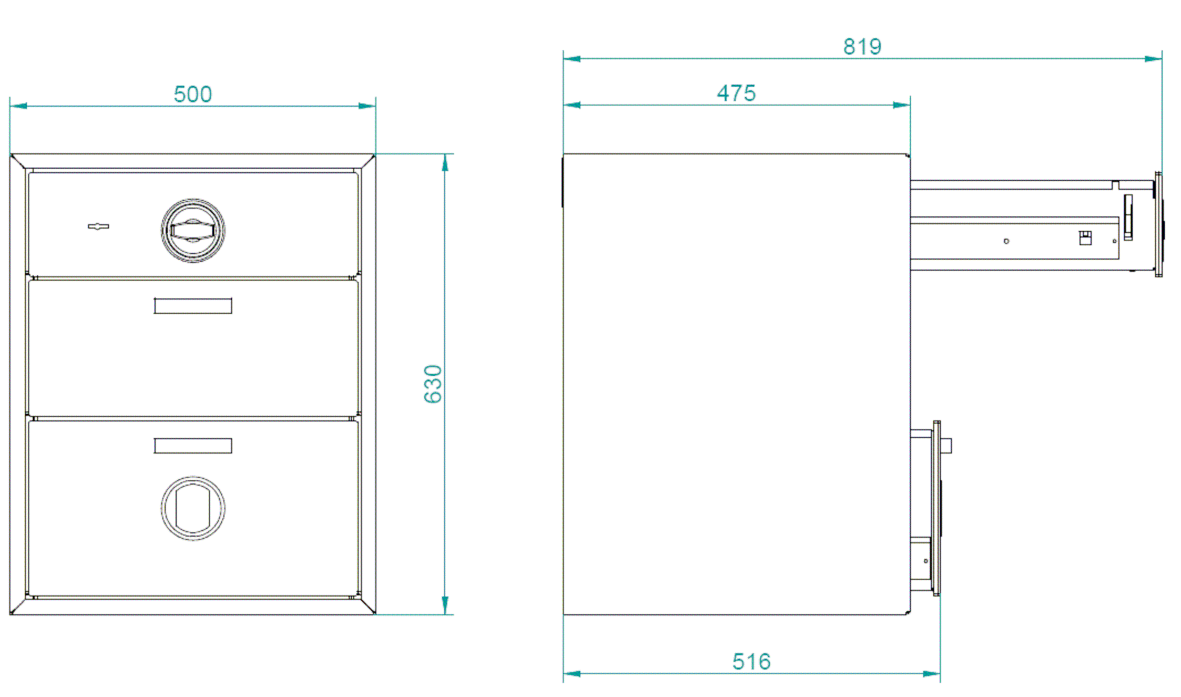

Body color, standard:

- Light-grey RAL 7035;
- Light-grey RAL 9002.

Operation:

- The device needs to be plugged into power supply network with protective earth.
- The device needs to be protected against humidity, and in case of spilling liquids over the device it needs to be immediately disconnected from the power supply and the service needs to be called.
- The service part of the device should not be opened. In case of failure the service should be called.

* We reserve the right to change the construction that would not influence the functionality and safety of the product.